



YLI ELECTRONIC

Shear Lock

Model: YM-2500SL



Specification

Voltage	12VDC (24VDC Adjustable)
Operation Current	1800mA
Standby	500mA
Time delay	0/5/10/15sec.
Door Sensor Output	NO/COM(0.1A@30VDC)
Lock Sensor Output	NO/NC/COM(0.1A@30VDC)
Shear Holding Force	1200kg
Door Gap	2.5mm
Magnet	265L X 30W X 30D(mm)
Amature	265L X 30W X 36.4D(mm)
Weight	1.782kg

Spec. Color	Wiring		
Red	+	Black	-
Gray	Lock Positions Sensor COM	Brown	Door Positions Sensor NO
Blue	Lock Status Sensor NO	White	Door Status Sensor COM
Green	Door Positions Sensor NO		

Time delay setting



Voltage setting

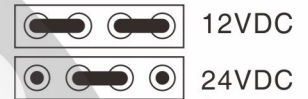

Dimensional Drawing (unit:mm)

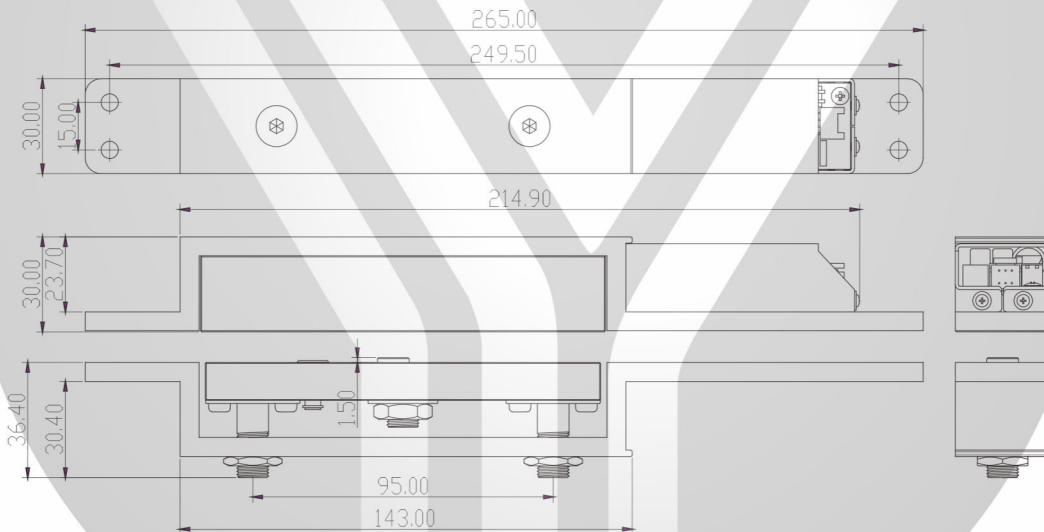

Installation Diagram

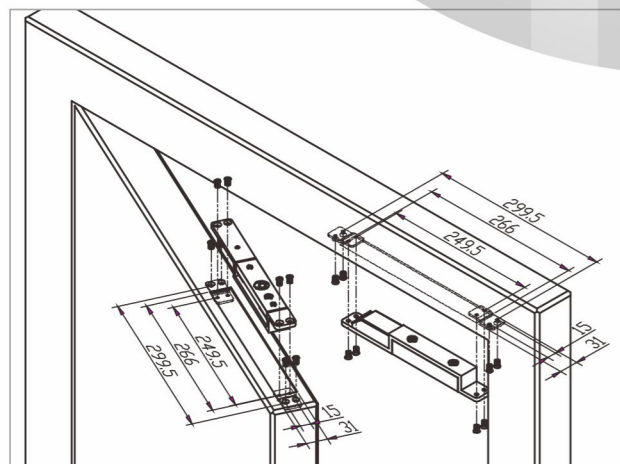

Installation

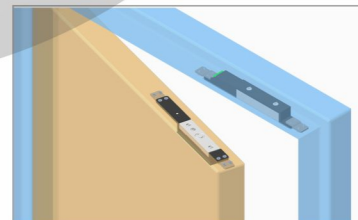

Solid door installation

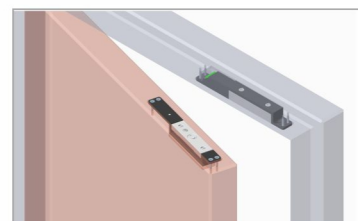

Hollow door installation

Trouble Shooting

Problems	Possible Cause	Solution
Door does not lock	The gap between the Armature Plate and the Shear Lock is exceeding 2.5mm.	Adjust the Armature Plate and arrange the gap between the Armature Plate and the Shear lock within 2.5mm.
	No power.	Electrically Checked with an Ammeter, it must be powered with the correct input voltage and checked to see if it draws the specified current.
	The door leaf does not return back at the correct position.	Positive centering door closers are required for all double acting door applicators to help attain consistent dead center alignment.
The Armature Plate keep repeating the magnetic attracting motion.	The gap between the Armature Plate and the Shear Lock is exceeding 2.5mm.	Adjust the Armature Plate and arrange the gap between the Armature Plate and the Shear lock within 2.5mm.
	Voltage and / or current is too low.	Electrically Checked with an Ammeter, it must be powered with the correct input voltage and checked to see if it draws the specified current.
	The gap between the Armature Plate and the Shear Lock is unequal.	Adjust the Armature Plate and make sure the gap between the Armature Plate and the Shear Lock is equal.
	The locking bolt does not correctly seat inside the keep hole of the Shear Lock.	Adjust the locking bolt of the Armature Plate and make sure it correctly seats inside the keep hole of the Shear Lock.
The Armature Plate is not at the right position and the locking bolt cannot seat correctly into the keep hole of the Shear Lock.	The position of the locking bolt is not correct.	Adjust the locking bolt of the Armature Plate and make sure it correctly seats inside the keep hole of the Shear Lock.
	The gap between the Armature Plate and the Shear Lock is unequal.	Adjust the Armature Plate and make sure the gap between the Armature Plate and the Shear Lock is equal.
	The setting of 'Auto Relocking time delay' is too short.	Adjust the setting of 'Locking time delay to appropriate.

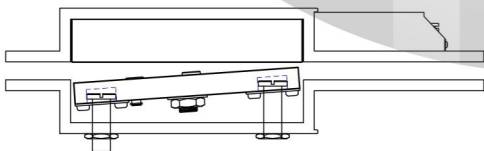
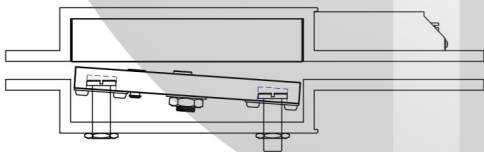
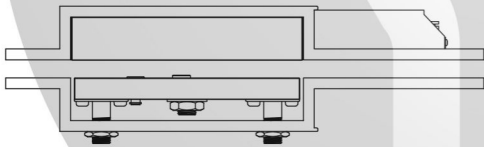

Make sure the gap between the Shear Lock and the Armature Plate are the same while adjusting the gap.

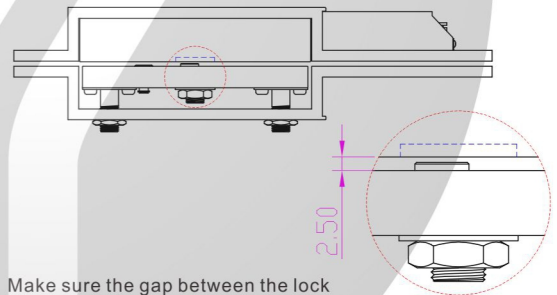

Make sure the gap between the lock and armature plate is within 2.5mm

Use the key wrench to adjust the gap between the armature plate and lock when the gap exceeds 2.5mm

